



SDH1608X SERIES ~ SMD Power Inductors



RoHS Compliant

PART NUMBERING SYSTEM

<u>SDH</u>	<u>1 6 0 8 X</u>	—	<u>1 R 0 M</u>	—	<u>LF</u>
TYPE	DIMENSIONS		INDUCTANCE		LEAD FREE

FEATURES :

- Low profile (height 2.92 mm max.)
- Available lead free and RoHS complaint
- Low cost and high reliability

SHAPES AND DIMENSIONS

UNIT : mm

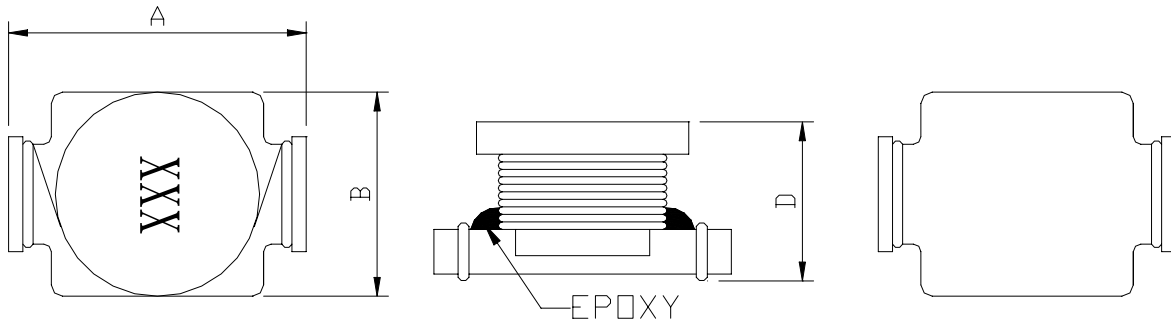

A = 6.6 Max. B = 4.45 Max. D = 2.92 Max.

RECOMMENDED PATTERNS

UNIT : mm

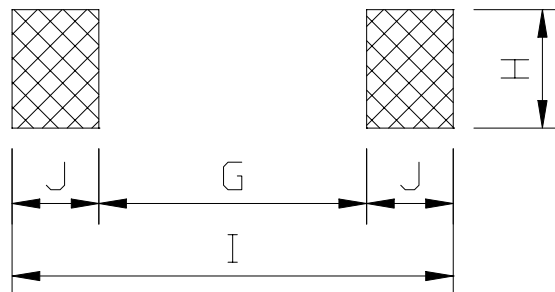
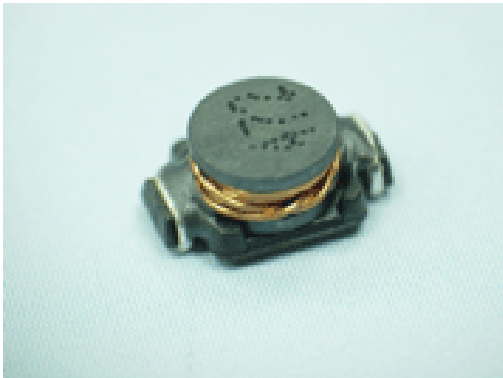

G = 4.06 H = 3.56 I = 6.86 J = 1.4



SDH1608X SERIES ~ SMD Power Inductors



RoHS Compliant

SPECIFICATION TABLE

PART NUMBER	INDUCTANCE (μ H)	DCR(Ω) (Max.)	Isat (A) (Max.)	Irms (A) (Max.)	SRF(MHz) (Ref.)
SDH1608X-1R0M-LF	1.0 \pm 20%	0.05	2.90	2.90	130
SDH1608X-1R5M-LF	1.5 \pm 20%	0.05	2.60	2.80	115
SDH1608X-2R2M-LF	2.2 \pm 20%	0.07	2.30	2.40	90
SDH1608X-2R7M-LF	2.7 \pm 20%	0.08	2.10	2.10	75
SDH1608X-3R3M-LF	3.3 \pm 20%	0.08	2.00	2.00	70
SDH1608X-4R7M-LF	4.7 \pm 20%	0.09	1.50	1.50	50
SDH1608X-6R8M-LF	6.8 \pm 20%	0.13	1.20	1.40	45
SDH1608X-8R2M-LF	8.2 \pm 20%	0.16	1.15	1.30	40
SDH1608X-100M-LF	10 \pm 20%	0.16	1.10	1.20	35
SDH1608X-150M-LF	15 \pm 20%	0.23	0.90	1.10	30
SDH1608X-220M-LF	22 \pm 20%	0.37	0.70	0.80	20
SDH1608X-330M-LF	33 \pm 20%	0.51	0.58	0.60	15
SDH1608X-470M-LF	47 \pm 20%	0.64	0.50	0.50	14
SDH1608X-680M-LF	68 \pm 20%	0.86	0.40	0.40	11
SDH1608X-101M-LF	100 \pm 20%	1.27	0.31	0.30	9
SDH1608X-151M-LF	150 \pm 20%	2.00	0.27	0.25	6
SDH1608X-221M-LF	220 \pm 20%	2.65	0.22	0.20	5.5
SDH1608X-331M-LF	330 \pm 20%	3.80	0.18	0.16	5
SDH1608X-471M-LF	470 \pm 20%	5.06	0.16	0.15	4
SDH1608X-681M-LF	680 \pm 20%	9.20	0.14	0.12	3
SDH1608X-102M-LF	1000 \pm 20%	13.80	0.10	0.07	2

1. Test Frequency ; Inductance tested at 100 kHz, 0.1 Vrms, 0 Adc.
2. Inductance is measured with a LCR meter 4284A or equivalent.
3. Inductance drop=10% typ. at rated current.
4. Operating temperature range -40°C to +125°C
5. Electrical specifications at 25°C



SDH1608X SERIES ~ SMD Power Inductors



PACKAGING SPECIFICATION

RoHS Compliant

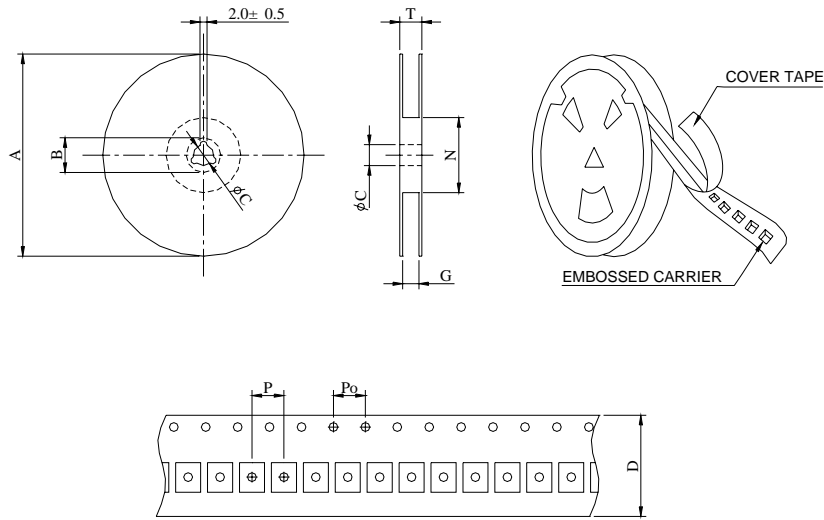

SERIES	STAYLE	Q' TY (PCS)	DIMENSIONS (m/m)								
			A	B±0.8	C±0.5	D	G ⁺⁰	N ⁰	P	Po	T
SDS1608X	13-16	2000	330	21	13	16	18	50	8	4	22.4