



SDS129 SERIES ~

SMD Shielded Power Inductors



RoHS Compliant

PART NUMBERING SYSTEM

SDS	1 2 9	—	1 0 0 M	—	L F
TYPE	DIMENSIONS		INDUCTANCE		LEAD FREE

SHAPES AND DIMENSIONS

UNIT : mm

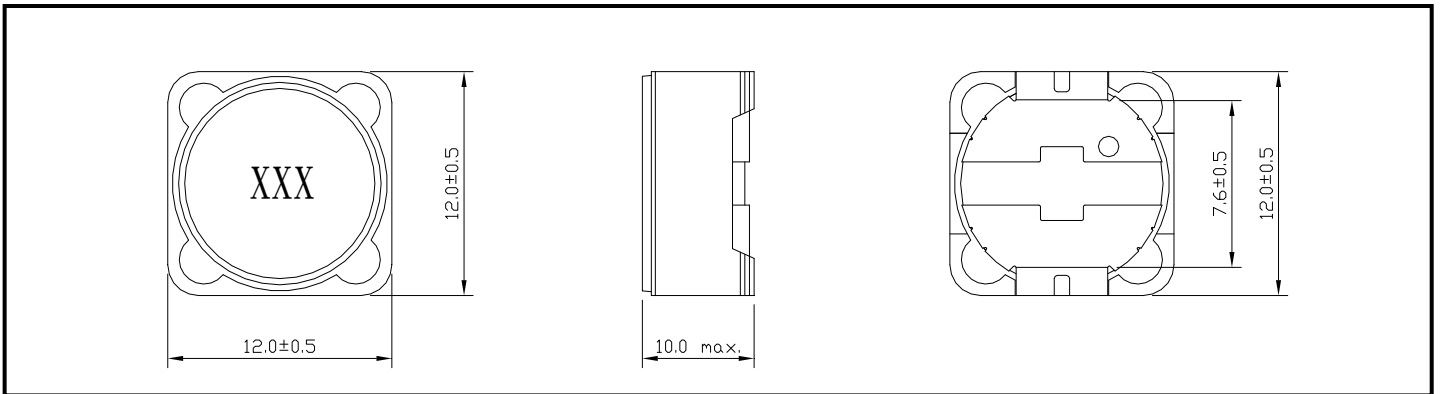

PACKAGING SPECIFICATION

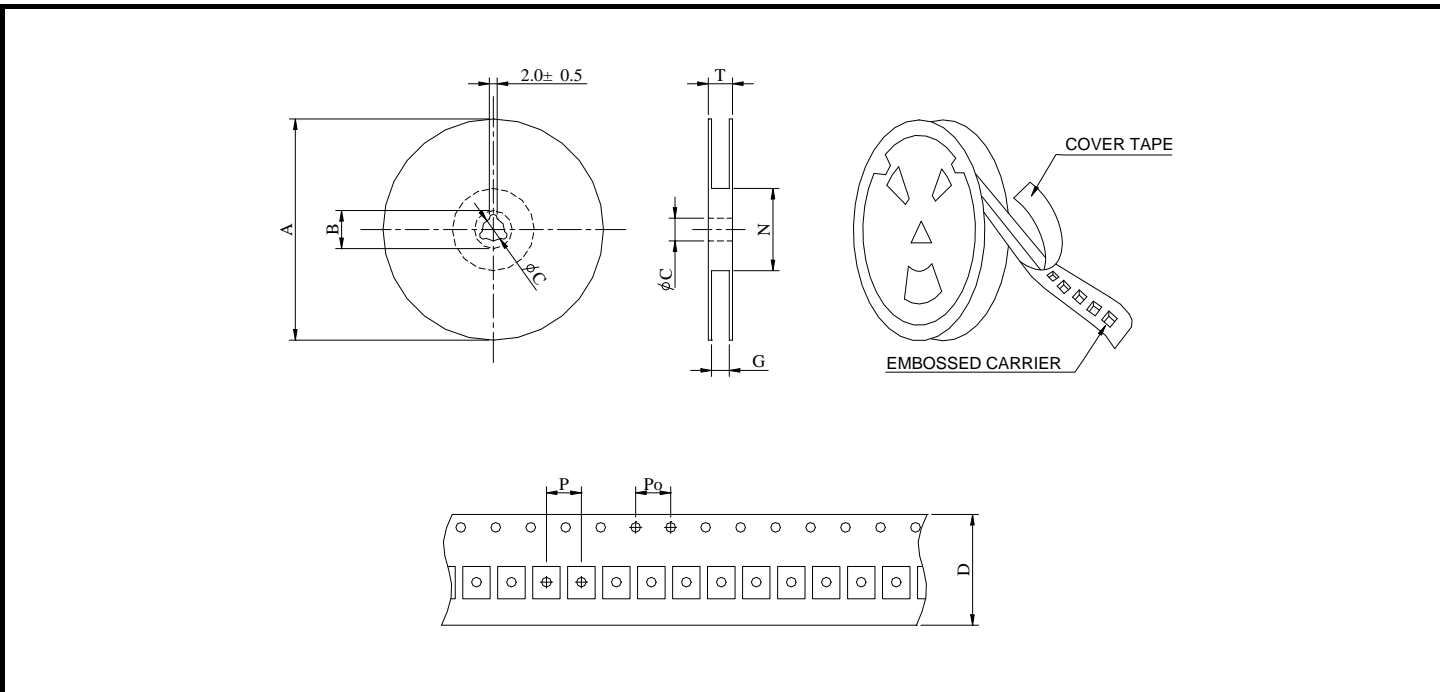

SERIES	STAYLE	Q' TY (PCS)	DIMENSIONS (m/m)								
			A	B ± 0.8	C ± 0.5	D	G $^{+0}$	N $^{-0}$	P	P $_0$	T
SDS129	13-24	400	330	21	13	24	26	50	20	4	30.4



SDS129 SERIES ~

SMD Shielded Power Inductors



RoHS Compliant

SPECIFICATION TABLE

PART NUMBER	INDUCTANCE (μ H)	DCR (Ω) (Max.)	Isat(A) (Max.)	Irms(A) (Max.)	TEST FREQ. (f)
SDS129-1R0N-LF	1.0 \pm 30%	5.6m	25.0	13.0	1KHz/0.25V
SDS129-2R2N-LF	2.2 \pm 30%	6.0m	20.0	11.5	1KHz/0.25V
SDS129-3R5N-LF	3.5 \pm 30%	8.5m	16.5	11.0	1KHz/0.25V
SDS129-4R7N-LF	4.7 \pm 30%	0.011	13.0	9.30	1KHz/0.25V
SDS129-6R8N-LF	6.8 \pm 30%	0.014	12.8	8.40	1KHz/0.25V
SDS129-100M-LF	10 \pm 20%	0.021	10.5	7.10	1KHz/0.25V
SDS129-150M-LF	15 \pm 20%	0.026	8.00	6.50	1KHz/0.25V
SDS129-220M-LF	22 \pm 20%	0.028	6.50	5.30	1KHz/0.25V
SDS129-330M-LF	33 \pm 20%	0.045	5.50	4.20	1KHz/0.25V
SDS129-470M-LF	47 \pm 20%	0.060	4.50	3.80	1KHz/0.25V
SDS129-680M-LF	68 \pm 20%	0.089	3.60	3.20	1KHz/0.25V
SDS129-101M-LF	100 \pm 20%	0.110	3.10	2.50	1KHz/0.25V
SDS129-151M-LF	150 \pm 20%	0.200	2.70	2.10	1KHz/0.25V
SDS129-221M-LF	220 \pm 20%	0.300	2.20	1.80	1KHz/0.25V
SDS129-331M-LF	330 \pm 20%	0.430	1.70	1.50	1KHz/0.25V
SDS129-471M-LF	470 \pm 20%	0.560	1.50	1.40	1KHz/0.25V

- DC current at which the inductance drops 10% (typ) from its value without current.
- Operating temperature range -40°C to +85°C.
- Electrical specifications at 20°C .
- **PLATING / SOLDER : TIN-SILVER-COPPER (95.5%/4.0%/0.5%)**