



# SQH3012S SERIES ~ **New Products**



## Low Profile SMD Power Inductors

### PART NUMBERING SYSTEM

<b>SQH</b>	<b>3 0 1 2 S</b>	—	<b>1 R 0 M</b>	—	<b>LF</b>
TYPE	DIMENSIONS		INDUCTANCE		LEAD FREE

### SHAPES AND DIMENSIONS

UNIT : mm

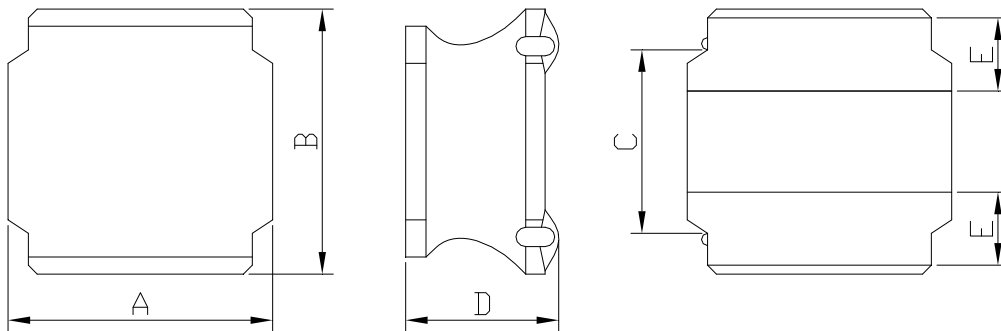

A=3.1 Max. B=3.1 Max. C=1.9±0.2 D=1.2 Max. E=0.9±0.2

### RECOMMENDED PATTERNS

UNIT : mm

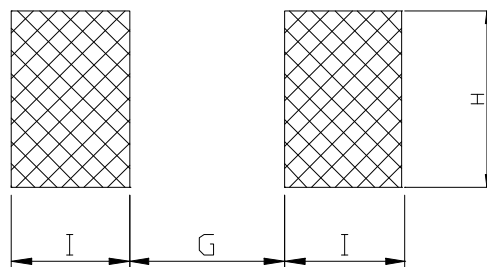

G= 1.40 H= 2.70 I = 0.80

### FEATURES

- \* Low profile and small inductors ( 3.1mm Max. square and 1.2mm Max. height )
- \* Magnetically shielded construction and high current
- \* Ideal for DC-DC converter choke coil for portable equipments ( DVDs , DSC , Cellular , PDAs )
- \* RoHS compliant option with lead free



# SQH3012S SERIES ~ **New Products**



RoHS Compliant

## Low Profile SMD Power Inductors

### SPECIFICATION TABLE

PART NUMBER	INDUCTANCE ( $\mu$ H)	DCR ( $\Omega$ ) (Max.)	Isat (mA) (Max.)	Irms (mA) (Max.)	TEST FREQ. ( f )
SQH3012S-1R0N-LF	1.0 $\pm$ 30%	0.060	1500	1490	100KHz
SQH3012S-1R5N-LF	1.5 $\pm$ 30%	0.072	1360	1400	100KHz
SQH3012S-2R2M-LF	2.2 $\pm$ 20%	0.096	1100	1200	100KHz
SQH3012S-3R3M-LF	3.3 $\pm$ 20%	0.120	910	1050	100KHz
SQH3012S-4R7M-LF	4.7 $\pm$ 20%	0.156	770	980	100KHz
SQH3012S-6R8M-LF	6.8 $\pm$ 20%	0.228	670	740	100KHz
SQH3012S-100M-LF	10 $\pm$ 20%	0.348	540	630	100KHz
SQH3012S-150M-LF	15 $\pm$ 20%	0.540	440	485	100KHz
SQH3012S-220M-LF	22 $\pm$ 20%	0.756	375	420	100KHz
SQH3012S-330M-LF	33 $\pm$ 20%	1.236	310	330	100KHz
SQH3012S-470M-LF	47 $\pm$ 20%	1.740	250	280	100KHz

- Isat : DC current at which the inductance drops 30%(typ) from its value without current.
- Irms : The temperature rise current value is the DC current value having temperature increase up 40°C temperature rise from 20°C ambient.
- Operating temperature range -40°C to +85°C , Electrical specifications at 20°C .